

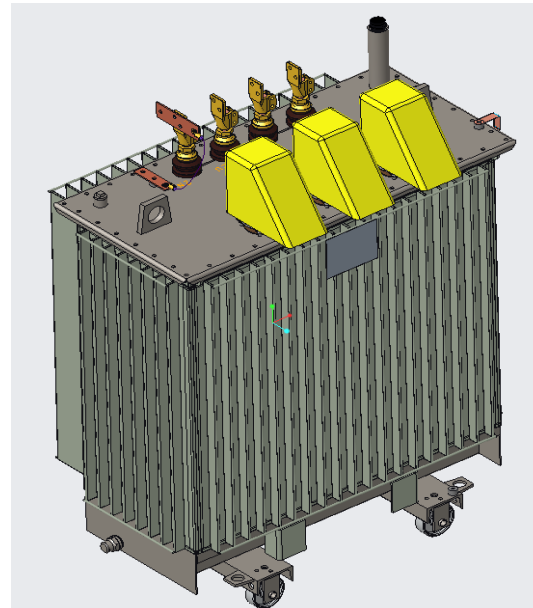

ENVIRONMENTAL PRODUCT DECLARATION

IN ACCORDANCE WITH EN 15804+A2 & ISO 14025

630 kVA – 10.5/0.4 kV De-energized tap changer Distribution Oil Filled Transformer
Kyte Powertech Limited



EPD HUB, HUB-5854

Published on 29.03.2026, last updated on 29.03.2026, valid until 29.03.2031

Life Cycle Assessment study has been performed in accordance with the requirements of EN 15804, EPD Hub PCR version 1.2 (24 Mar 2025) and JRC characterization factors EF 3.1.



Created with One Click LCA



GENERAL INFORMATION

MANUFACTURER

Manufacturer	Kyte Powertech Limited
Address	Cavan, Ireland H12KV20
Contact details	orders@kytepowertech.com
Website	https://www.kytepowertech.com/

EPD STANDARDS, SCOPE AND VERIFICATION

Program operator	EPD Hub, hub@epdhub.com
Reference standard	EN 15804:2012+A2:2019/AC:2021 and ISO 14025
PCR	EPD Hub Core PCR Version 1.2, 24 Mar 2025
Sector	Electrical product
Category of EPD	Third party verified EPD
Parent EPD number	-
Scope of the EPD	Cradle to gate with options A4–A5, B6 and modules C1–C4, D
EPD author	Levin Parackal, Kyte Powertech
EPD verification	Independent verification of this EPD and data, according to ISO 14025: <input type="checkbox"/> Internal verification <input checked="" type="checkbox"/> External verification
EPD verifier	Magaly Gonzalez Vazquez as an authorized verifier for EPD Hub

This EPD is intended for business-to-business and/or business-to-consumer communication. The manufacturer has the sole ownership, liability, and responsibility for the EPD. EPDs within the same product category but from different programs may not be comparable. EPDs of construction products may not be comparable if they do not comply with EN 15804 and if they are not compared in a building context.

PRODUCT

Product name	630 kVA – 10.5/0.4 kV De-energized tap changer Distribution Oil Filled Transformer
Additional labels	-
Product reference	ZENA0025018
Place(s) of raw material origin	China, UK, Italy, Ireland
Place of production	Cavan, Ireland H12KV20
Place(s) of installation and use	Netherlands
Period for data	Calendar year 2024
Averaging in EPD	No grouping
Variation in GWP-fossil for A1-A3 (%)	-
GTIN (Global Trade Item Number)	-
NOBB (Norwegian Building Product Database)	-
A1-A3 Specific data (%)	32,6

ENVIRONMENTAL DATA SUMMARY

Declared unit	1 unit of a 630 kVA, 10.5/0.4 kV oil-immersed distribution transformer (hermetically sealed), manufactured by Kyte Powertech Limited in Cavan, Ireland
Declared unit mass	2425 kg
Mass of packaging	10 kg
GWP-fossil, A1-A3 (kgCO₂e)	12300
GWP-total, A1-A3 (kgCO₂e)	12300
Secondary material, inputs (%)	14,6
Secondary material, outputs (%)	63,7
Total energy use, A1-A3 (kWh)	54800
Net freshwater use, A1-A3 (m³)	207

PRODUCT AND MANUFACTURER

ABOUT THE MANUFACTURER

Established in 1977 in Cavan, Ireland, Kyte Powertech has evolved into a prominent player in the electrical sector, specializing in the development of tailored, high-quality transformer solutions. Operating from its expansive 17,500 sqm production facility with a yearly capacity of 6,500 MVA, the company manufactures and delivers a diverse range of products and services. With enduring alliances and strategic partnerships, some exceeding 25 years, Kyte Powertech has solidified its position as a market leader. The organization serves utilities in the United Kingdom, Ireland, Belgium, and the Netherlands, offering an extensive portfolio that spans industrial applications, wind and solar solutions, electric vehicle charging stations, and battery storage solutions.

PRODUCT DESCRIPTION

3-Phase 630 kVA – 10.5/0.4 kV De-energized Tap Changer Distribution Oil-Filled Transformer with transformer number as ZENA0025018.

Manufactured by Kyte Powertech Limited, Cavan, Ireland. The product is unambiguously identified as a 630 kVA oil-immersed distribution transformer designed and manufactured in accordance with applicable IEC standards for power transformers.

Technical and Functional Characteristics

The transformer is designed for medium-to-low voltage electrical energy distribution networks and operates under the following technical specifications:

- Rated power: 630 kVA
- Frequency: 50 Hz
- Primary voltage (HV): 10.5 kV
- Secondary voltage (LV): 400 V

- Vector group: Dyn5
- Cooling method: ONAN (Oil Natural Air Natural)
- Short-circuit impedance (uk): 4%
- Maximum operating voltage (Um): 12 kV
- Power frequency withstand voltage (AC): 28 kV
- Lightning impulse withstand voltage (LI): 75 kV
- Environmental class: A

The transformer is hermetically sealed and filled with mineral insulating oil, which provides both electrical insulation and thermal management. The core is constructed from grain-oriented silicon steel to minimize magnetic losses. Windings are manufactured from aluminum conductors with oil-impregnated paper insulation. The unit includes a de-energized tap changer for voltage adjustment.

Relevant Technical Data and Reference Service Life (RSL)

The declared Reference Service Life (RSL) is 30 years, assuming normal operating conditions and appropriate maintenance within electrical distribution networks.

Intended Application

The transformer is intended for use in electrical energy distribution networks, typically installed in substations or distribution points within industrial, commercial, and residential power systems.

Applicable Standards and Testing

The product is designed and tested in accordance with applicable IEC standards for power transformers, including but not limited to: IEC 60076 series (Power Transformers)

Routine, type, and special tests are performed according to the relevant IEC standards before dispatch.

Further information can be found at: <https://www.kytechpowertech.com/>

PRODUCT RAW MATERIAL MAIN COMPOSITION

Raw material category	Amount, mass %	Material origin
Metals	80	China, EU, Italy
Minerals	-	-
Fossil materials	17,5	Ireland, EU
Bio-based materials	2,5	Ireland, UK, EU

BIOGENIC CARBON CONTENT

Product's biogenic carbon content at the factory gate

Biogenic carbon content in product, kg C	26,91
Biogenic carbon content in packaging, kg C	3,61

FUNCTIONAL UNIT AND SERVICE LIFE

Declared unit	1 unit of a 630 kVA, 10.5/0.4 kV oil-immersed distribution transformer (hermetically sealed), manufactured by Kyte Powertech Limited in Cavan, Ireland
Mass per declared unit	2425 kg
Functional unit	Delivery of electrical energy through operation of 1 unit of a 630 kVA, 10.5/0.4 kV oil-immersed distribution transformer (Dyn5, ONAN) over a reference service life (RSL) of 30 years, including no-load and load losses supplied by the regional electricity grid mix.
Reference service life	30 Years

SUBSTANCES, REACH - VERY HIGH CONCERN

The product does not contain any REACH SVHC substances in amounts greater than 0,1 % (1000 ppm).

PRODUCT LIFE-CYCLE

SYSTEM BOUNDARY

This EPD covers the life-cycle modules listed in the following table.

Product stage			Assembly stage		Use stage	End of life stage				Beyond the system boundaries		
A1	A2	A3	A4	A5	B6	C1	C2	C3	C4	D		
x	x	x	x	x	x	x	x	x	x	x		
Raw materials	Transport	Manufacturing	Transport	Assembly	Operational energy use	Deconstruction/demolition	Transport	Waste processing	Disposal	Reuse	Recovery	Recycling

MANUFACTURING AND PACKAGING (A1-A3)

The environmental impacts considered for the product stage cover the manufacturing of raw materials used in the production as well as packaging materials and other ancillary materials. Also, fuels used by machines, and handling of waste formed in the production processes at the manufacturing facilities are included in this stage. The study also considers the material losses occurring during the manufacturing processes as well as losses during electricity transmission.

A market-based approach is used in modelling the electricity mix utilized in the factory.

Energy sources profile (A3):

Manufacturing energy consumption includes electricity, LPG/propane for process heating. Electricity is modelled using a **market-based** factory electricity mix based on contractual supply and on-site generation (grid electricity and solar PV). All energy data are based on factory utility records and allocated to the declared unit using the production mass allocation factor.

A3 manufacturing waste treatment assumptions (percentages and references):

Manufacturing waste generation is based on verified production loss/scrap rates and includes metal scrap (steel, aluminium, copper), insulation offcuts (paper/pressboard), packaging residues (wood/cardboard/plastics), paint residues, and wastewater. Metal scrap is assumed to be 100% sent to recycling, consistent with typical industrial practice and EN 50693 default treatment routes for metals. Non-metal waste streams are treated using European average waste treatment datasets in One Click LCA/Ecoinvent (e.g., paper sorting/recycling routes, plastic recycling/landfill routes, paint landfill route, wastewater treatment). Where EN 50693 provides default end-of-life assumptions, these were used as the reference framework for material-specific treatment representativeness, together with One Click LCA database datasets.

Transport assumptions for A3 waste:

Transport of manufacturing waste to treatment facilities is modelled using a conservative average truck transport distance of **250 km** from the manufacturing site to waste treatment/recycling facilities (European average assumption). This distance is applied consistently across A3 waste flows where site-specific waste contractor distances are not available.

The use of green energy in manufacturing is demonstrated through contractual instruments (GOs, RECs, etc.), and its use is ensured throughout the validity period of this EPD.

TRANSPORT AND INSTALLATION (A4-A5)

A4 – Transport to Installation Site

The transportation distance from the production plant to the installation site is modelled as 236 km by lorry and 1163 km by ship, based on average delivery distances. Heavy goods vehicle transport (>32 metric ton, EURO5) and ocean freight datasets from Ecoinvent 3.10/3.11 are applied. A vehicle capacity utilisation factor of 50% is assumed. Empty return trips are not considered, assuming transport providers utilise return journeys for other deliveries. Transportation losses are assumed negligible due to proper packaging of the transformer.

A5 – Packaging Waste Treatment Assumptions

Packaging materials at installation consist of wooden supports and cardboard packaging. Packaging waste is modelled using the One Click LCA EU packaging end-of-life scenario datasets (“A5 x EoL Wood packaging EU scenario” and related EU datasets). These datasets apply European average waste treatment routes, including recycling, energy recovery (incineration), and landfill according to EU statistical waste treatment shares. No manual percentage split was applied; treatment fractions are defined within the referenced EU scenario datasets, consistent with EN 15804+A2 and EN 50693.

A5 – Packaging Waste Transport Assumptions

Transport of packaging waste is modelled according to the embedded assumptions within the One Click LCA EU end-of-life scenario datasets. Where transport is explicitly represented, heavy goods vehicle transport

(>32 metric ton, EURO5) is applied using European average distances consistent with the EU waste treatment scenario.

No additional installation energy use is required for placement of the transformer.

PRODUCT USE AND MAINTENANCE (B6)

During the use phase, the transformer consumes electricity to compensate for internal losses, including core (no-load) losses and winding (load) losses. These losses are supplied by the regional electricity grid mix, and associated environmental impacts include emissions from electricity generation and transmission losses.

Reference Service Life (RSL)

The Reference Service Life (RSL) of the transformer is declared as 30 years, in accordance with typical service life expectations for oil-immersed distribution transformers operating under standard European grid conditions.

The RSL is based on:

- Compliance with IEC 60076 series standards for power transformers
- Insulation system design and thermal class
- Hermetically sealed mineral oil system
- Normal operating conditions (continuous operation at 50 Hz)
- Proper installation and standard preventive maintenance

The declared RSL assumes:

- Operation within rated voltage and load conditions
- Ambient environmental conditions corresponding to Environmental Class A
- No major overloading beyond design limits

- Regular inspection in accordance with utility practices
No material replacement is assumed during the 30-year reference period.

PRODUCT END OF LIFE (C1-C4, D)

C1–C4 – End-of-Life Scenarios

Energy use during dismantling (C1) is assumed negligible. Transport to waste treatment facilities (C2) is modelled as 100 km by lorry (>32 t, EURO5) under European average conditions.

Waste processing and disposal (C3–C4) are modelled using EN 50693 default European end-of-life datasets available in One Click LCA. No manual percentage splits were applied; treatment shares are embedded within the EN 50693 datasets, reflecting European average recycling, incineration and landfill rates.

The following treatments are applied:

- Steel, aluminium, copper: Modelled using EN 50693 transformer recycling datasets reflecting high European recycling rates for metals.
- Mineral oil: Modelled as hazardous waste incineration (European average).
- Oil-impregnated paper and pressboard: Modelled according to EN 50693 default electricity equipment scenario, including embedded European average shares of sorting, recycling, incineration with energy recovery and landfill.
- Rubber components: Treated according to EN 50693 default electricity equipment waste scenario (European average).
- Paint residues: Modelled as sanitary landfill (EU average dataset).

- Wood packaging: Modelled using EU average wood waste treatment scenario (energy recovery and landfill fractions embedded in dataset).
- Cardboard packaging: Modelled using EU average recycling dataset.

All treatment modelling is based on EN 50693 and EN 15804+A2 compliant datasets within the One Click LCA database.

Module D – System Boundary, Substitution and Assumptions

System Boundary

Module D includes potential environmental benefits and loads beyond the system boundary, starting at the point where materials reach end-of-waste state after C3–C4 processing and enter secondary material or energy markets.

The following flows are included in Module D:

- Recycled metals (steel, aluminium, copper)
- Energy recovered from incineration of oil-impregnated paper, mineral oil and wood packaging
- Packaging materials treated at end-of-life (wood and cardboard)

Landfilled materials (paint residues, non-recyclable rubber fractions, inert waste) do not generate Module D benefits.

Packaging materials are included under the same substitution logic as product materials where recycling or energy recovery occurs.

MANUFACTURING PROCESS

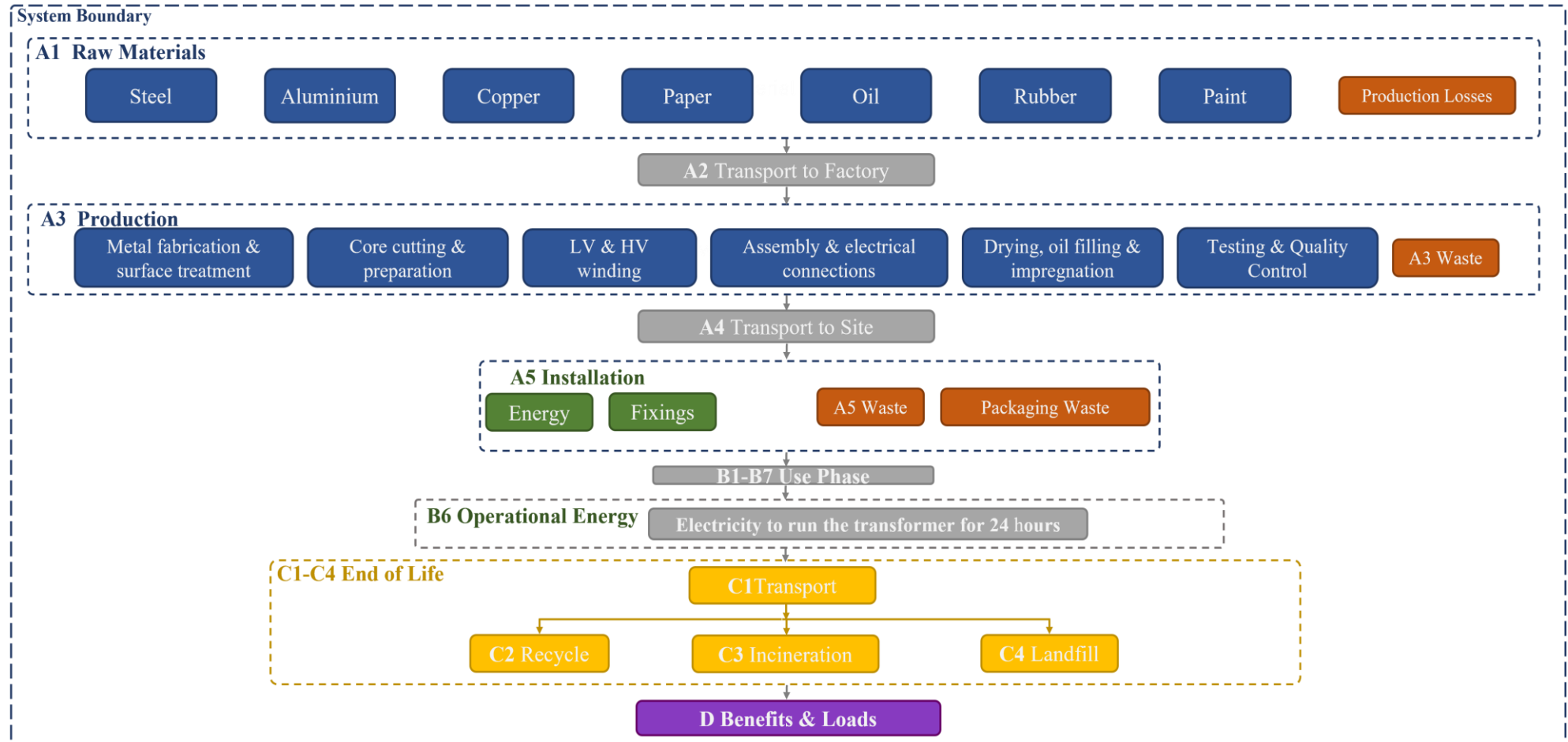

LIFE-CYCLE ASSESSMENT

CUT-OFF CRITERIA

The study does not exclude any modules or processes which are stated mandatory in the reference standard and the applied PCR. The study does not exclude any hazardous materials or substances. The study includes all major raw material and energy consumption. All inputs and outputs of the unit processes, for which data is available for, are included in the calculation. There is no neglected unit process more than 1% of total mass or energy flows. The module specific total neglected input and output flows also do not exceed 5% of energy usage or mass.

The production of capital equipment, construction activities, and infrastructure, maintenance and operation of capital equipment, personnel-related activities, energy and water use related to company management and sales activities are excluded.

No life-cycle stages were excluded from the assessment. Minor components such as fasteners, nuts, bolts, and miscellaneous small items could not be modelled individually due to lack of specific datasets. Their mass (31.7 kg) was conservatively included by proportionally increasing the mass of the main material categories

VALIDATION OF DATA

Data collection for production, transport, and packaging was conducted using time and site-specific information, as defined in the general information section on page 1 and 2. Upstream process calculations rely on generic data as defined in the Bibliography section. Manufacturer-provided specific and generic data were used for the product’s manufacturing stage. The analysis was performed in One Click LCA EPD Generator, with the 'Cut-Off, EN 15804+A2' allocation method, and characterization factors according to EN 15804:2012+A2:2019/AC:2021 and JRC EF 3.1.

ALLOCATION, ESTIMATES AND ASSUMPTIONS

Allocation is required if some material, energy, and waste data cannot be measured separately for the product under investigation. All allocations are done as per the reference standards and the applied PCR. In this study, allocation has been done in the following ways:

Data type	Allocation
Raw materials	No allocation
Packaging material	No allocation
Ancillary materials	Allocated by mass or volume
Manufacturing energy and waste	Allocated by mass or volume

Minor miscellaneous components (e.g. nuts, bolts, fasteners, small fittings) with a total mass of 31.7 kg could not be individually categorised due to data limitations. To ensure mass completeness and conservative modelling, this mass was proportionally distributed across the main material categories (steel, aluminium, copper, rubber, and other relevant materials) based on their relative contribution to the total product mass.

Packaging quantities were derived from the product bill of materials and normalised to the declared unit based on mass. Manufacturing energy, ancillary materials, and manufacturing waste were allocated to the declared unit based on mass, in accordance with EN 15804.

End-of-life scenarios were modelled using EN 50693 compliant datasets and EU average waste treatment assumptions. Transport distances to waste treatment facilities were assumed based on conservative default values where site-specific data was unavailable

PRODUCT & MANUFACTURING SITES GROUPING

Type of grouping	No grouping
Grouping method	Not applicable
Variation in GWP-fossil for A1-A3, %	-

There is no average result considered in this study since this EPD refers to one specific product product in one production plant.

LCA SOFTWARE AND BIBLIOGRAPHY

This EPD has been created using One Click LCA EPD Generator for EPD Hub V3 and EPD Process Certification v3.2.3. The LCA and EPD have been prepared according to the reference standards and ISO 14040/14044. The EPD Generator uses Ecoinvent v3.10.1/3.11 and One Click LCA databases as sources of environmental data. Allocation used in Ecoinvent 3.10.1/3.11 environmental data sources follow the methodology ‘allocation, Cut-off, EN 15804+A2’.

Bibliography and References Used in Modeling

Standards and PCR

EN 15804:2012+A2:2019 Sustainability of construction works –

- Environmental product declarations – Core rules for the product category of construction products.

EN 50693:2019 Product category rules for power transformers, distribution transformers and reactors.

- ECO Platform Standards – Verification Guidelines v8.0 (December 2024). Background LCA Database

One Click LCA database (2024 release).

- Ecoinvent database v3.10 / v3.11 – European datasets.
- European Commission waste statistics (embedded within Ecoinvent and EN 50693 default scenarios).

A4 Transport

- Ecoinvent datasets:
- Transport, freight, lorry >32 metric ton, EURO5
- Transport, freight, sea, ocean ship
- Transport distances based on project-specific logistics assessment and average delivery distances.

A5 Installation and Packaging Waste

One Click LCA EU packaging end-of-life scenario datasets.

European average waste treatment shares embedded in Ecoinvent datasets.

B6 Operational Energy

- IEC 60076 series – Power transformers.
- Transformer losses (no-load and load losses) based on product technical specifications.
- Electricity modelled using market-based electricity mix datasets (One Click LCA / Ecoinvent European electricity datasets).

C1–C4 End-of-Life

- EN 50693 default European end-of-life scenarios (EI3.10).

Ecoinvent datasets for:

- Recycling of metals
- Hazardous waste incineration (mineral oil)
- Waste treatment of paper, rubber, paint
- European average landfill processes

Module D – Substitution

- EN 15804+A2 avoided burden approach.
- Substitution of primary steel, aluminium, copper production based on European average Ecoinvent datasets.

Primary Data Sources

- Kyte Powertech Limited factory utility records (electricity, LPG, water).
- Product Bill of Materials (BOM).
- Production scrap rates and waste tracking records (2024 reporting year).
- Transport logistics data from supplier declarations and internal procurement records.

ENVIRONMENTAL IMPACT DATA

The estimated impact results are only relative statements which do not indicate the end points of the impact categories, exceeding threshold values, safety margins or risks.

CORE ENVIRONMENTAL IMPACT INDICATORS – EN 15804+A2, EF 3.1

Impact category	Unit	A1	A2	A3	A1-A3	A4	A5	B1	B2	B3	B4	B5	B6	B7	C1	C2	C3	C4	D
GWP – total ¹⁾	kg CO ₂ e	8,24E+03	3,41E+03	6,32E+02	1,23E+04	3,67E+02	3,61E+01	ND	ND	ND	ND	ND	1,92E+05	ND	0,00E+00	8,03E+01	1,35E+02	1,21E+03	-3,49E+03
GWP – fossil	kg CO ₂ e	8,24E+03	3,40E+03	6,36E+02	1,23E+04	3,67E+02	1,85E+01	ND	ND	ND	ND	ND	1,91E+05	ND	0,00E+00	8,03E+01	4,43E+01	1,20E+03	-3,39E+03
GWP – biogenic	kg CO ₂ e	-9,34E+01	7,70E-01	-4,34E+00	-9,70E+01	8,31E-02	1,76E+01	ND	ND	ND	ND	ND	-2,02E+01	ND	0,00E+00	1,74E-02	9,05E+01	1,00E+01	-3,71E+01
GWP – LULUC	kg CO ₂ e	9,03E+01	1,52E+00	1,23E-01	9,20E+01	1,64E-01	2,38E-03	ND	ND	ND	ND	ND	6,19E+01	ND	0,00E+00	3,55E-02	4,88E-02	1,12E-02	-5,87E+01
Ozone depletion pot.	kg CFC ₋₁₁ e	1,30E-04	5,03E-05	2,04E-05	2,01E-04	5,42E-06	2,74E-07	ND	ND	ND	ND	ND	4,71E-03	ND	0,00E+00	1,13E-06	4,46E-07	3,03E-07	-4,27E-05
Acidification potential	mol H ⁺ e	4,20E+01	1,16E+01	1,44E+00	5,50E+01	1,25E+00	1,64E-01	ND	ND	ND	ND	ND	6,92E+02	ND	0,00E+00	2,68E-01	4,42E-01	1,40E-01	-1,90E+01
EP-freshwater ²⁾	kg Pe	4,11E+00	2,65E-01	8,14E-02	4,46E+00	2,86E-02	6,78E-04	ND	ND	ND	ND	ND	9,27E+01	ND	0,00E+00	6,24E-03	2,24E-02	7,86E-02	-1,75E+00
EP-marine	kg Ne	7,16E+00	3,81E+00	3,16E-01	1,13E+01	4,11E-01	7,73E-02	ND	ND	ND	ND	ND	1,58E+02	ND	0,00E+00	8,68E-02	9,95E-02	5,91E-02	-2,66E+00
EP-terrestrial	mol Ne	7,14E+01	4,15E+01	3,24E+00	1,16E+02	4,47E+00	8,33E-01	ND	ND	ND	ND	ND	1,68E+03	ND	0,00E+00	9,44E-01	1,11E+00	6,20E-01	-2,92E+01
POCP (“smog”) ³⁾	kg NMVOCe	3,98E+01	1,71E+01	1,33E+00	5,83E+01	1,84E+00	2,49E-01	ND	ND	ND	ND	ND	5,04E+02	ND	0,00E+00	3,74E-01	3,27E-01	1,56E-01	-1,14E+01
ADP-minerals & metals ⁴⁾	kg Sbe	4,60E-02	9,50E-03	1,58E-03	5,71E-02	1,02E-03	7,44E-06	ND	ND	ND	ND	ND	2,77E+00	ND	0,00E+00	2,62E-04	2,41E-03	9,63E-05	-2,33E-02
ADP-fossil resources	MJ	1,28E+05	4,94E+04	8,46E+03	1,86E+05	5,32E+03	2,41E+02	ND	ND	ND	ND	ND	2,43E+06	ND	0,00E+00	1,13E+03	4,90E+02	2,38E+02	-4,51E+04
Water use ⁵⁾	m ³ e depr.	8,87E+03	2,44E+02	4,32E+01	9,15E+03	2,63E+01	7,78E-01	ND	ND	ND	ND	ND	4,07E+04	ND	0,00E+00	5,24E+00	8,20E+00	1,74E+01	-4,62E+03

1) GWP = Global Warming Potential; 2) EP = Eutrophication potential. Required characterisation method and data are in kg P-eq. Multiply by 3,07 to get PO4e; 3) POCP = Photochemical ozone formation; 4) ADP = Abiotic depletion potential; 5) EN 15804+A2 disclaimer for Abiotic depletion and Water use and optional indicators except Particulate matter and Ionizing radiation, human health. The results of these environmental impact indicators shall be used with care as the uncertainties on these results are high or as there is limited experience with the indicator.

ADDITIONAL (OPTIONAL) ENVIRONMENTAL IMPACT INDICATORS – EN 15804+A2, EF 3.1

Impact category	Unit	A1	A2	A3	A1-A3	A4	A5	B1	B2	B3	B4	B5	B6	B7	C1	C2	C3	C4	D
Particulate matter	Incidence	5,86E-04	3,41E-04	7,83E-06	9,35E-04	3,67E-05	4,66E-06	ND	ND	ND	ND	ND	3,57E-03	ND	0,00E+00	6,42E-06	6,23E-06	5,38E-06	-2,46E-04
Ionizing radiation ⁶⁾	kBq 11235e	1,27E+03	4,30E+01	5,79E+00	1,32E+03	4,64E+00	1,13E-01	ND	ND	ND	ND	ND	3,36E+03	ND	0,00E+00	9,18E-01	1,81E+00	5,68E-01	-6,07E+02
Ecotoxicity (freshwater)	CTUe	2,48E+04	6,99E+03	5,13E+03	3,69E+04	7,53E+02	1,40E+02	ND	ND	ND	ND	ND	6,43E+06	ND	0,00E+00	1,77E+02	4,28E+02	2,79E+04	5,69E+02
Human toxicity, cancer	CTUh	1,24E-05	5,62E-07	6,81E-08	1,30E-05	6,05E-08	2,01E-09	ND	ND	ND	ND	ND	4,83E-05	ND	0,00E+00	1,36E-08	3,43E-08	1,08E-07	-3,75E-06
Human tox. non-cancer	CTUh	9,14E-05	3,20E-05	2,29E-06	1,26E-04	3,45E-06	3,79E-08	ND	ND	ND	ND	ND	2,50E-03	ND	0,00E+00	7,06E-07	2,15E-06	2,02E-06	5,15E-05
SQP ⁷⁾	-	2,11E+04	4,97E+04	2,35E+03	7,32E+04	5,36E+03	2,01E+01	ND	ND	ND	ND	ND	8,86E+05	ND	0,00E+00	6,87E+02	9,16E+02	2,36E+02	-9,70E+03

6) EN 15804+A2 disclaimer for Ionizing radiation, human health. This impact category deals mainly with the eventual impact of low-dose ionizing radiation on human health of the nuclear fuel cycle. It does not consider effects due to possible nuclear accidents, occupational exposure nor due to radioactive waste disposal in underground facilities. Potential ionizing radiation from the soil, from radon and from some construction materials is also not measured by this indicator; 7) SQP = Land use related impacts/soil quality.

USE OF NATURAL RESOURCES

Impact category	Unit	A1	A2	A3	A1-A3	A4	A5	B1	B2	B3	B4	B5	B6	B7	C1	C2	C3	C4	D
Renew. PER as energy ⁸⁾	MJ	2,80E+04	6,77E+02	8,61E+02	2,95E+04	7,30E+01	-1,45E+02	ND	ND	ND	ND	ND	9,29E+05	ND	0,00E+00	1,55E+01	-7,08E+02	-8,55E+01	-1,70E+04
Renew. PER as material	MJ	5,02E+02	0,00E+00	8,21E+01	5,84E+02	0,00E+00	-1,35E+02	ND	ND	ND	ND	ND	0,00E+00	ND	0,00E+00	0,00E+00	-4,01E+02	-4,81E+01	3,72E+02
Total use of renew. PER	MJ	2,85E+04	6,77E+02	9,44E+02	3,01E+04	7,30E+01	-2,80E+02	ND	ND	ND	ND	ND	9,29E+05	ND	0,00E+00	1,55E+01	-1,11E+03	-1,34E+02	-1,66E+04
Non-re. PER as energy	MJ	1,10E+05	4,94E+04	8,00E+03	1,68E+05	5,32E+03	2,41E+02	ND	ND	ND	ND	ND	2,43E+06	ND	0,00E+00	1,13E+03	4,71E+02	-1,45E+04	-4,52E+04
Non-re. PER as material	MJ	1,76E+04	0,00E+00	-5,28E+02	1,71E+04	0,00E+00	0,00E+00	ND	ND	ND	ND	ND	0,00E+00	ND	0,00E+00	0,00E+00	-1,28E+00	-1,71E+04	1,96E+00
Total use of non-re. PER	MJ	1,28E+05	4,94E+04	7,48E+03	1,85E+05	5,32E+03	2,41E+02	ND	ND	ND	ND	ND	2,43E+06	ND	0,00E+00	1,13E+03	4,69E+02	-3,16E+04	-4,52E+04
Secondary materials	kg	3,54E+02	2,10E+01	1,87E+00	3,76E+02	2,27E+00	1,01E-01	ND	ND	ND	ND	ND	6,98E+02	ND	0,00E+00	5,06E-01	5,83E-01	3,70E-01	1,13E+03
Renew. secondary fuels	MJ	2,89E+00	2,67E-01	1,83E-02	3,18E+00	2,88E-02	2,90E-04	ND	ND	ND	ND	ND	1,66E+01	ND	0,00E+00	6,44E-03	2,54E-02	2,02E-03	-5,33E-01
Non-ren. secondary fuels	MJ	0,00E+00	0,00E+00	0,00E+00	0,00E+00	0,00E+00	0,00E+00	ND	ND	ND	ND	ND	0,00E+00	ND	0,00E+00	0,00E+00	0,00E+00	0,00E+00	0,00E+00
Use of net fresh water	m ³	1,99E+02	7,30E+00	1,04E+00	2,07E+02	7,87E-01	2,36E-03	ND	ND	ND	ND	ND	9,44E+02	ND	0,00E+00	1,50E-01	2,19E-01	-2,30E-01	-1,38E+02

8) PER = Primary energy resources.

END OF LIFE – WASTE

Impact category	Unit	A1	A2	A3	A1-A3	A4	A5	B1	B2	B3	B4	B5	B6	B7	C1	C2	C3	C4	D
Hazardous waste	kg	2,50E+03	8,37E+01	2,19E+01	2,61E+03	9,02E+00	2,96E-01	ND	ND	ND	ND	ND	1,54E+04	ND	0,00E+00	1,96E+00	4,10E+00	1,10E+01	-1,14E+03
Non-hazardous waste	kg	1,98E+04	1,55E+03	8,54E+02	2,22E+04	1,67E+02	1,73E+01	ND	ND	ND	ND	ND	4,63E+05	ND	0,00E+00	3,68E+01	1,15E+02	9,04E+02	9,67E+03
Radioactive waste	kg	3,35E-01	1,05E-02	1,40E-03	3,47E-01	1,13E-03	2,78E-05	ND	ND	ND	ND	ND	8,23E-01	ND	0,00E+00	2,25E-04	4,47E-04	1,45E-04	-1,62E-01

END OF LIFE – OUTPUT FLOWS

Impact category	Unit	A1	A2	A3	A1-A3	A4	A5	B1	B2	B3	B4	B5	B6	B7	C1	C2	C3	C4	D
Components for re-use	kg	0,00E+00	0,00E+00	0,00E+00	0,00E+00	0,00E+00	0,00E+00	ND	ND	ND	ND	ND	0,00E+00	ND	0,00E+00	0,00E+00	0,00E+00	0,00E+00	0,00E+00
Materials for recycling	kg	0,00E+00	0,00E+00	0,00E+00	0,00E+00	0,00E+00	3,20E+00	ND	ND	ND	ND	ND	0,00E+00	ND	0,00E+00	0,00E+00	1,54E+03	0,00E+00	0,00E+00
Materials for energy rec	kg	0,00E+00	0,00E+00	0,00E+00	0,00E+00	0,00E+00	0,00E+00	ND	ND	ND	ND	ND	0,00E+00	ND	0,00E+00	0,00E+00	0,00E+00	0,00E+00	0,00E+00
Exported energy	MJ	0,00E+00	0,00E+00	0,00E+00	0,00E+00	0,00E+00	1,59E+01	ND	ND	ND	ND	ND	0,00E+00	ND	0,00E+00	0,00E+00	3,41E+01	0,00E+00	0,00E+00
Exported energy – Electricity	MJ	0,00E+00	0,00E+00	0,00E+00	0,00E+00	0,00E+00	6,70E+00	ND	ND	ND	ND	ND	0,00E+00	ND	0,00E+00	0,00E+00	1,42E+01	0,00E+00	0,00E+00
Exported energy – Heat	MJ	0,00E+00	0,00E+00	0,00E+00	0,00E+00	0,00E+00	9,20E+00	ND	ND	ND	ND	ND	0,00E+00	ND	0,00E+00	0,00E+00	1,99E+01	0,00E+00	0,00E+00

ENVIRONMENTAL IMPACTS – EN 15804+A1, CML

Impact category	Unit	A1	A2	A3	A1-A3	A4	A5	B1	B2	B3	B4	B5	B6	B7	C1	C2	C3	C4	D
Global Warming Pot.	kg CO ₂ e	8,29E+03	3,39E+03	6,34E+02	1,23E+04	3,65E+02	1,86E+01	ND	ND	ND	ND	ND	1,91E+05	ND	0,00E+00	7,99E+01	4,49E+01	1,21E+03	-3,43E+03
Ozone depletion Pot.	kg CFC ₁₁ e	1,09E-04	4,01E-05	1,67E-05	1,66E-04	4,32E-06	2,19E-07	ND	ND	ND	ND	ND	4,19E-03	ND	0,00E+00	9,01E-07	3,70E-07	2,52E-07	-3,58E-05
Acidification	kg SO ₂ e	3,53E+01	8,86E+00	1,17E+00	4,53E+01	9,55E-01	1,15E-01	ND	ND	ND	ND	ND	5,55E+02	ND	0,00E+00	2,05E-01	3,55E-01	9,83E-02	-1,61E+01
Eutrophication	kg PO ₄ ³ e	5,96E+00	2,16E+00	1,79E-01	8,30E+00	2,33E-01	2,73E-02	ND	ND	ND	ND	ND	1,23E+02	ND	0,00E+00	4,99E-02	5,16E-02	5,32E-02	-4,74E-01
POCP (“smog”)	kg C ₂ H ₄ e	4,24E+00	7,90E-01	8,41E-02	5,11E+00	8,51E-02	8,70E-03	ND	ND	ND	ND	ND	3,52E+01	ND	0,00E+00	1,84E-02	2,14E-02	7,89E-03	-2,23E+00
ADP-elements	kg Sbe	4,45E-02	9,26E-03	1,55E-03	5,53E-02	9,98E-04	7,20E-06	ND	ND	ND	ND	ND	2,75E+00	ND	0,00E+00	2,56E-04	2,40E-03	6,24E-05	-2,25E-02
ADP-fossil	MJ	1,06E+05	4,87E+04	8,18E+03	1,63E+05	5,25E+03	2,39E+02	ND	ND	ND	ND	ND	2,38E+06	ND	0,00E+00	1,11E+03	4,62E+02	2,28E+02	-3,47E+04

ADDITIONAL INDICATOR – GWP-GHG

Impact category	Unit	A1	A2	A3	A1-A3	A4	A5	B1	B2	B3	B4	B5	B6	B7	C1	C2	C3	C4	D
GWP-GHG ⁹⁾	kg CO ₂ e	8,33E+03	3,41E+03	6,36E+02	1,24E+04	3,67E+02	1,85E+01	ND	ND	ND	ND	ND	1,92E+05	ND	0,00E+00	8,03E+01	4,43E+01	1,20E+03	-3,45E+03

9) This indicator includes all greenhouse gases excluding biogenic carbon dioxide uptake and emissions and biogenic carbon stored in the product. In addition, the characterisation factors for the flows – CH₄ fossil, CH₄ biogenic and Dinitrogen monoxide – were updated. This indicator is identical to the GWP-total of EN 15804:2012+A2:2019 except that the characterisation factor for biogenic CO₂ is set to zero.

SCENARIO DOCUMENTATION

DATA SOURCES

Manufacturing energy scenario documentation

1. Electricity production, photovoltaic, 3kWp slanted-roof installation, multi-Si, panel, mounted, Ireland, Ecoinvent, 0.0777 kgCO_{2e}/kWh
2. Heat production, propane, at industrial furnace >100kW, World, Ecoinvent, 0.0945 kgCO_{2e}/MJ
3. Electricity, medium voltage, residual mix, Ireland, Ecoinvent, 0.55 kgCO_{2e}/kWh

Transport scenario documentation - A4 (Transport resources)

1. Market for transport, freight, lorry >32 metric ton, EURO5, 236 km
2. Market for transport, freight, lorry >32 metric ton, EURO5, 1163.06 km

Transport scenario documentation A4

Scenario parameter	Value
Capacity utilization (including empty return) %	50
Bulk density of transported products	1,31E+03
Volume capacity utilization factor	<1

Installation scenario documentation - A5 (Installation resources)

1. Diesel, burned in building machine, Ecoinvent, 180.0 MJ

Installation scenario documentation - A5 (Installation waste)

1. Exported Energy: Electricity, Ecoinvent, 6.7 MJ
2. Exported Energy: Thermal, Ecoinvent, 9.2 MJ
3. Treatment of waste wood, post-consumer, sorting and shredding, Ecoinvent, Materials for recycling, 3.2 kg
4. Treatment of waste wood, untreated, municipal incineration, Ecoinvent, 3.0 kg
5. Treatment of waste wood, untreated, sanitary landfill, Ecoinvent, 3.8 kg

Use stages scenario documentation - B6 (Energy data source)

1. Electricity, low voltage, residual mix, Netherlands, Ecoinvent, 413850.0 kWh

Use stages scenario documentation - B7 (Water data source)

Use stages scenario documentation - B6-B7 Use of energy and use of water

Scenario information	Value
Ancillary materials specified by material / kg or units as appropriate	No ancillary materials are required during the use stage under normal operating conditions. The transformer is a sealed oil-filled unit and does not require routine consumables during operation.
Characteristic performance, e.g., energy efficiency, emissions, variation of performance with capacity utilization, etc.	The transformer is designed to deliver 630 kVA electrical power at a primary voltage of 10.5 kV and a secondary voltage of 400 V. Operational energy performance is represented through transformer load and no-load losses during the reference service life. The transformer operates continuously under normal grid conditions with typical load variation depending on network demand.
Further assumptions for scenario development, e.g., frequency and period of use, number of occupants	The transformer is assumed to operate continuously over a reference service life of 30 years under standard European grid conditions. Average loading conditions are assumed to reflect typical

distribution network demand. No abnormal operating conditions, overload events, or exceptional maintenance scenarios are considered.

End-of-life scenario documentation - C1-C4 (Data source)

1. Treatment of waste paper, unsorted, sorting, Ecoinvent, Materials for recycling, 31.84 kg
2. Exported Energy: Thermal, Ecoinvent, 9.59 MJ
3. Exported Energy: Thermal, Ecoinvent, 4.28 MJ
4. Exported Energy: Thermal, Ecoinvent, 1.84 MJ
5. Exported Energy: Thermal, Ecoinvent, 4.147 MJ
6. Exported Energy: Electricity, Ecoinvent, 6.9 MJ
7. Exported Energy: Electricity, Ecoinvent, 2.98 MJ
8. Exported Energy: Electricity, Ecoinvent, 1.34 MJ
9. Exported Energy: Electricity, Ecoinvent, 3.0173 MJ
10. Treatment of waste packaging paper, sanitary landfill, Ecoinvent, 3.45 kg
11. Treatment of waste packaging paper, sanitary landfill, Ecoinvent, 1.6752 kg
12. Treatment of waste packaging paper, municipal incineration, Ecoinvent, 3.069 kg
13. Treatment of waste packaging paper, municipal incineration, Ecoinvent, 1.49 kg
14. Treatment of waste paperboard, unsorted, sorting, Ecoinvent, Materials for recycling, 15.449 kg
15. Treatment of waste wood, post-consumer, sorting and shredding, Ecoinvent, Materials for recycling, 0.64 kg
16. Treatment of waste wood, untreated, sanitary landfill, Ecoinvent, 0.76 kg
17. Treatment of waste wood, untreated, municipal incineration, Ecoinvent, 0.6 kg
18. Treatment of waste mineral oil, hazardous waste incineration, Ecoinvent, 420.495 kg
19. Treatment of waste emulsion paint, sanitary landfill, Ecoinvent, 10.284 kg
20. Sorting and pressing of iron scrap, Ecoinvent, Materials for recycling, 1.13 kg
21. Sorting and pressing of iron scrap, Ecoinvent, Materials for recycling, 356.103 kg

- 22. Sorting and pressing of iron scrap, Ecoinvent, Materials for recycling, 1139.24 kg
- 23. Treatment of scrap steel, inert material landfill, Ecoinvent, 0.75 kg
- 24. Treatment of scrap steel, inert material landfill, Ecoinvent, 284.81 kg
- 25. Treatment of waste aluminium, sanitary landfill, Ecoinvent, 152.615 kg
- 26. Treatment of waste rubber, unspecified, municipal incineration, Ecoinvent, 0.72 kg
- 27. Treatment of waste rubber, unspecified, municipal incineration, Ecoinvent, 0.36 kg
- 28. Treatment of waste plastic, mixture, sanitary landfill, Ecoinvent, 0.36 kg

Scenario information	Value
Scenario assumptions e.g. transportation	End-of-life treatment follows EN 50693 default scenarios for electrical equipment. Metals are assumed to be recycled according to European average recycling rates. Transformer oil is modelled as hazardous waste incineration. Paint residues are modelled as landfill disposal. Rubber, paper, and wood follow standard European treatment routes. Transportation to waste treatment facilities is assumed as 50 km by truck.

THIRD-PARTY VERIFICATION STATEMENT

EPD Hub declares that this EPD is verified in accordance with ISO 14025 by an independent, third-party verifier. The project report on the Life Cycle Assessment and the report(s) on features of environmental relevance are filed at EPD Hub. EPD Hub PCR and ECO Platform verification checklist are used.

EPD Hub is not able to identify any unjustified deviations from the PCR and EN 15804+A2 in the Environmental Product Declaration and its project report.

EPD Hub maintains its independence as a third-party body; it was not involved in the execution of the LCA or in the development of the declaration and has no conflicts of interest regarding this verification.

The company-specific data and upstream and downstream data have been examined as regards plausibility and consistency. The publisher is responsible for ensuring the factual integrity and legal compliance of this declaration.

The software used in creation of this LCA and EPD is verified by EPD Hub to conform to the procedural and methodological requirements outlined in ISO 14025:2010, ISO 14040/14044, EN 15804+A2, and EPD Hub Core Product Category Rules and General Program Instructions.

Verified tools

Tool verifier: Magaly Gonzalez Vazquez

Tool verification validity: 27 March 2025 - 26 March 2028

Magaly Gonzalez Vazquez as an authorized verifier for EPD Hub Limited
29.03.2026

